

5 inch Round Aluminum Light Poles

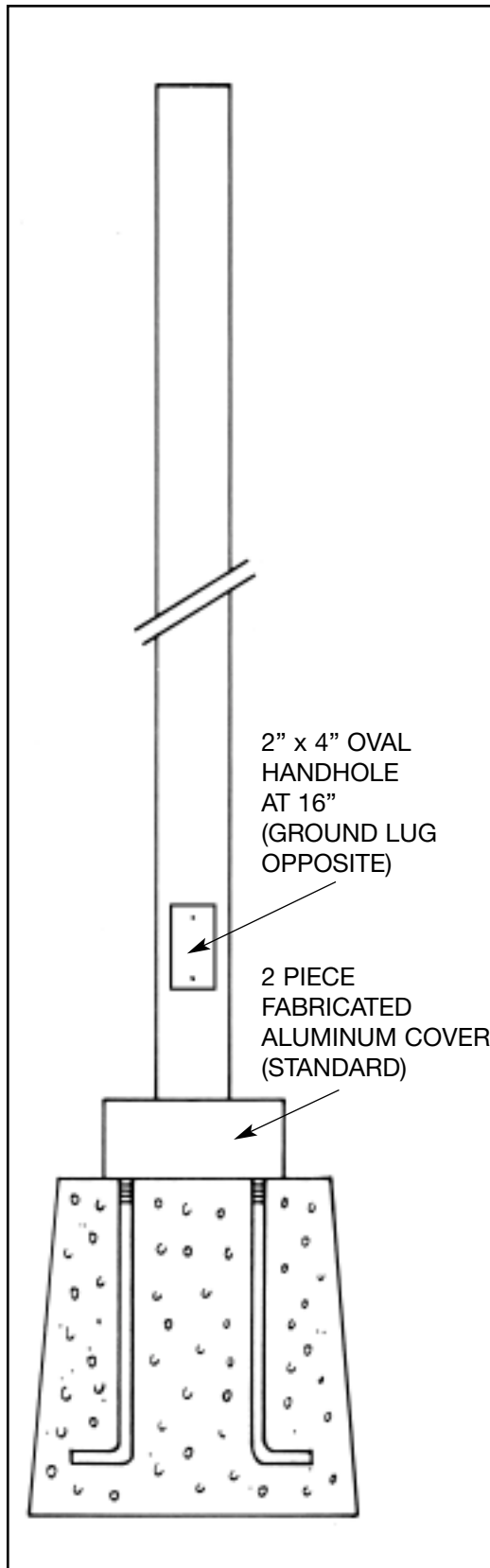

MATERIAL:

Extrusions: 6063-T6

Castings: 356-T6

Hardware: 18-8 Stainless Steel

WELDMENTS:

Process: M.I.G.

All NAFCO welders are certified
by the State of Wisconsin

AVAILABLE FINISHES:

Anodized; Bronze, Black or Satin

Painted

OPTIONS:

Tenons to your specifications

Removable cap when drilling for arms

Duplex outlets

Vibration Dampeners

Other options available
by consulting NAFCO

NOTE:

All NAFCO aluminum light poles are age
hardened after welding to restore the
structural integrity of the pole.

NAFCO POLE BASES ARE DESIGNED TO BE IN DIRECT CONTACT WITH THE
CONCRETE FOUNDATIONS. SHOULD A LEVELING NUT BE USED, IT IS
IMPERATIVE THAT THE SPACE BETWEEN THE BASE AND FOUNDATION BE
COMPLETELY FILLED WITH GROUT TO PREVENT SEVERE STRUCTURAL
DAMAGE TO THE POLE.

*Serving our customers and
the industry with quality
products since 1973.*

5 inch Round Aluminum Light Poles

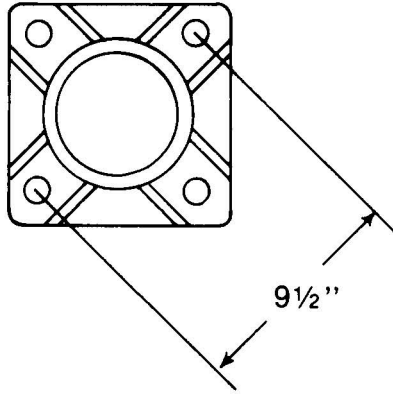

Base Cover: 6" x 10¹/₂" SQ.
Bolt Circle: 9¹/₂"
Bolt Projection: 3¹/₂"
Bolt Finish: Hot-Dipped Galvanized

POLE CATALOG NUMBER	MOUNTING HEIGHT	WALL THICKNESS	SHIPPING WEIGHT	ANCHOR BOLT SIZE	Max EPA AT: (Allows for 1.3 Gust Factor)				
					80 MPH	90 MPH	100 MPH	110 MPH	120 MPH
5R15D	15'	.188	66	3/4"X18"X3"	13.7	10.1	7.5	6.6	5.3
5R20D	20'	.188	85	3/4"X18"X3"	7.7	5.1	3.3	2.7	2.1
5R20E	20'	.250	106	3/4"X18"X3"	11.2	7.9	5.5	4.7	3.7
5R25E	25'	.250	130	3/4"X18"X3"	6.2	3.8	2.0	1.5	1.0

All LTL shipped NAFCO 5" poles are wrapped in double wall 275# test corrugate for protection in shipment.

Variations in mounting heights listed are available.